



Takasago Global Network



List of Overseas Group Companies

- 1 Takasago Constructors and Engineers (China) Co., Ltd.**  
26GHI Oriental Kenzo Plaza, 48 Dongzhimenwai Ave. Beijing 10027, P.R. of China  
Tel: +86-10-8454-9488  
<http://www.takasago.cn/>
- 2 Takasago Singapore Pte. Ltd.**  
1 Jalan Kilang Timor #08-01, Pacific Tech Centre Singapore 159303  
TEL: +65-6737-3312  
<http://www.takasago.com.sg>
- 3 Thai Takasago Co., Ltd.**  
Bangna Towers C 16th Fl., 40/14 Moo 12, Bangna-Trad Rd., K. M. 6. 5, Bangkaew, Bangplee, Samutprakarn 10540 Thailand  
TEL: +66-2-751-9695  
<https://www.thaitakasago.co.th>
- 4 T.T.E. Engineering (Malaysia) Sdn. Bhd.**  
Lot No. 01-7, 7th Floor, Menara Symphony, No. 5, Jalan Prof. Khoo Kay Kim, Seksyen 13, 46200 Petaling Jaya, Selangor Malaysia.  
TEL: +60-3-7955-5972  
<https://www.ttemalaysia.com.my>
- 5 Takasago Thermal Engineering (Hong Kong) Co., Ltd.**  
Unit A, 15/F., Yardley Commercial Building, 3 Connaught Road West, Hong Kong  
TEL: +852-2520-2403  
<http://www.takasago.com.hk>
- 6 Takasago Vietnam Co., Ltd.**  
19th Floor, IDMC My Dinh Building, No. 15 Pham Hung Street, My Dinh 2 Ward, Nam Tu Liem District, Hanoi, Vietnam  
TEL: +84-24-6275-1932  
<http://takasagovietnam.vn/>
- 7 PT. Takasago Thermal Engineering**  
Gedung Mugi Griya, Jl. MT. Haryono, 4th Floor, Unit 406, Tebet, Jakarta Selatan 12810, Indonesia  
TEL: +62-21-8370-8518  
<http://takasago.co.id/>
- 8 Takasago Thermal Engineering Co., Ltd. Myanmar Branch Office**  
Aurora Business Tower, 40, No (1) Industrial Road, Bahan Township, Yangon, Myanmar  
TEL: +95-9-457-598-770  
<https://takasagomyanmar.com.mm/>
- 9 Takasago Engineering Mexico, S.A. de C.V.**  
Anillo Vial 2 Fray Junipero Serra, Pabellon Santa Fe #2601 Piso 4, Residencial Juriquilla Santa Fe, Queratro, QRO., Mexico  
TEL: +52-1-442-325-4545  
TEL: +52-1-442-217-1054  
<http://takasago-mexico.com>
- 10 Integrated Cleanroom Technologies Pvt. Ltd.**  
Integrated Cleanroom Technologies Private Limited, 3rd Floor, Ratna Arcade, Sy. No. 126-128, Kompally, Hydenabad - 500014 Telangana, India  
TEL: +91-40-2716-5311 TEL: +91-40-2716-5316  
<https://www.icleantech.com>

Contact information regarding this pamphlet

Takasago Thermal Engineering Co.,Ltd.  
International Business Headquarters

12F SHINJUKU EASTSIDE SQUARE, 6-27-30 SHINJUKU,  
SHINJUKU-KU, TOKYO, 160-0022, JAPAN



Published in  
June 2023

# GreenAir® Tech

## GREEN AIR TECHNOLOGY GROUP PROFILE



## CONTENTS

<p><b>Environmental Solutions</b> 11</p> <ul style="list-style-type: none"> <li>Converting to environmentally friendly energy</li> <li>Development of a city with locally produced and locally consumed energy</li> <li>Green Air® service</li> <li>Hydrogen energy system</li> </ul> <p><b>Industrial Solutions</b> 13</p> <ul style="list-style-type: none"> <li>TCR-SWIT®</li> <li>TCR-FFU</li> <li>DRY ROOM® technology</li> <li>Energy-saving type dehumidifier: WINDS® series</li> <li>Chemical washer: T-GET® C</li> <li>Green Air® IDC and IDC-S<sub>Flow</sub>®</li> </ul> <p><b>Energy Management</b> 16</p> <ul style="list-style-type: none"> <li>Energy management system: GDoc®</li> <li>Gathering operation data and analysis: GODA® CLOUD</li> <li>Total system for measurement, analysis, and evaluation: MAT®</li> </ul> <p><b>Equipment / Systems</b> 18</p> <ul style="list-style-type: none"> <li>Drainless flushing system</li> <li>Super ice system for high freshness: SIS-HF®</li> <li>Hybrid outdoor air handling unit</li> <li>Micro gas engine cogeneration system: μCGS-F50</li> <li>Medical clean booth: BARRIFLOW® III/</li> <li>Medical clean hood: BARRIHOOD®</li> <li>Swirling induction type TAKASAGO HVAC system: SWIT®</li> <li>Aluminum refrigerant piping system</li> </ul>	<p>11</p> <p>13</p> <p>16</p> <p>18</p>
--	---

## Initiatives for a sustainable society

As “environmental solution professionals that can affect the global environment,” we create and promote technology and products that contribute to the development of a decarbonized and sustainable society. We will work together with society to achieve our goal for 2030, while ensuring that our activities contribute to the achievement of the SDGs.

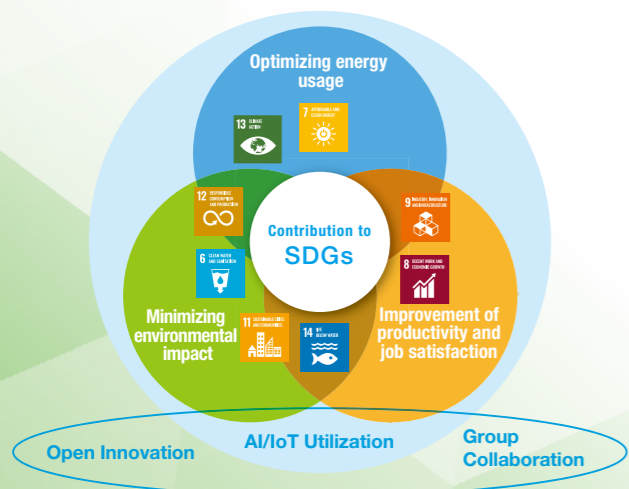

## Company Outline

<b>Company name</b>	Takasago Thermal Engineering Co., Ltd.
<b>Established</b>	November 16, 1923
<b>Capital</b>	13,134 million yen
<b>Listed</b>	On the Prime Section of the Tokyo Stock Exchange
<b>Address</b>	6-27-30, Shinjuku, Shinjuku-ku, Tokyo 160-0022
<b>Number of employees</b>	5,885 (consolidated, as of March 31, 2023)

## List of Overseas Group Companies

Takasago Constructors and Engineers (China) Co., Ltd.  
 Takasago Singapore Pte. Ltd.  
 Thai Takasago Co., Ltd.  
 T.T.E. Engineering (Malaysia) Sdn. Bhd.  
 Takasago Thermal Engineering (Hong Kong) Co., Ltd.  
 Takasago Vietnam Co., Ltd.  
 PT. Takasago Thermal Engineering  
 Takasago Thermal Engineering Co., Ltd. Myanmar Branch Office  
 Takasago Engineering Mexico, S.A. de C.V.  
 Integrated Cleanroom Technologies Pvt. Ltd.

## Takasago Global Network



**Sustainable Development Goals (SDGs)**

These are the Sustainable Development Goals (SDGs), which the world has agreed to strive to meet by 2030.

**SUSTAINABLE DEVELOPMENT GOALS**  
17 GOALS TO TRANSFORM OUR WORLD

We aim to contribute to SDGs through our business activities.

## Message from the President



小島 和人  
**Kazuhito Kojima**  
 President and Representative Director, COO

Takasago Thermal Engineering Co., Ltd. will celebrate the 100th anniversary of its founding on November 16, 2023.

Over the years, our company has transformed itself repeatedly in response to changing times, in line with our Corporate Mission, which emphasizes “Contribution to society through personal harmony and creativity,” and, as a company that supports industrial and social infrastructure, we have continued to develop our business with a focus on air conditioning systems.

As we reach the milestone of our 100th anniversary, we have been rethinking the meaning of the company’s existence, and we have defined the purpose of the Takasago Thermal Engineering Group as being “Creating a brighter future for the world through environmental innovation.”

In accordance with this purpose, every Takasago employee will be moving forward together as an Environment-Creator®.

We have also formulated the Takasago Thermal Engineering Group Long-term Vision 2040. To help solve social issues with an eye on the future, we will be working toward the realization of the “Carbon transition within the building environment” and of the “Carbon neutral for the global environment.” The Takasago Thermal Engineering Group as a whole will be pooling its capabilities and constantly challenging itself as an Environment-Creator®, aiming to be a company that works together with its business partners to co-create environmental value.

May 2023

## Management Philosophy

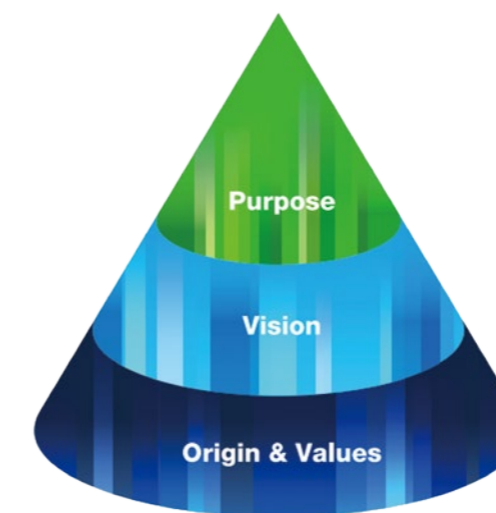

### Purpose

**With our revolutionary environmental innovations, we activate the Earth’s future.**

Takasago Thermal Engineering synchronizes the air to various spatial environments, creating endless possibilities. Moreover, each employee is part of a tradition of pride and expertise built over the Company’s 100-year history, and we continue to expand the spirit of diversity and co-creation through harmonious relationships with others. We consistently pioneer paradigm-shifting environmental innovations. We are able to create optimized spatial environments not only on this planet, but also in space. And we are profoundly dedicated to the wellbeing of our families, our fellow human beings, and all life on Earth.

### Vision

**Be an Environment-Creator™.**

### Origin

**Contribute to society through social harmony and creative solutions.**

### Values

Provide value **beyond** expectations.  
 Act with fairness, confidence, and **pride**.  
 Build **trust** to create enduring relationships.



**From a pioneer of HVAC systems to becoming an Environmental-Creator®**  
**Our 100-year history leading into the future**

The company started out as Takasago Heating Works Co., Ltd. in 1923, the year of the Great Kanto Earthquake, and has continued in operation through the Taisho, Showa, and Heisei eras into the Reiwa era. Today, under the name Takasago Thermal Engineering Co., Ltd., the company is still a pioneer in HVAC system. As a company that supports industrial and social infrastructure, we have continued to take on challenges in advanced technology as professionals trusted by customers and as pioneers of optimal systems and equipment.



Looking toward the future, Takasago Thermal Engineering Group will continue to evolve as an Environment-Creator® that swiftly and flexibly responds to customers' needs, and which aims to help build a sustainable society. We will be working toward the realization of saving energy through the "Carbon transition within the building environment" and of CO<sub>2</sub> net zero emission through the "Carbon neutral for the global environment," focusing on the provision of general air conditioning systems that create comfortable, optimal spatial environments, and industrial air conditioning systems that meet the needs of high-end precision manufacturing.

# History of Green Air® Technology

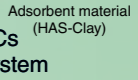

Green solutions

2010 Ozone wastewater treatment system*	2014 Treatment of spiral RO membrane and UF membrane	2020 Adsorbent thermal storage system Mega Stock® 
2012 Hydrogen energy system	2015 Energy produced locally for local consumption* 	2021 Closed VOCs recycling system 

Energy management

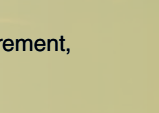
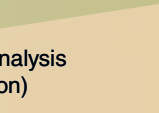





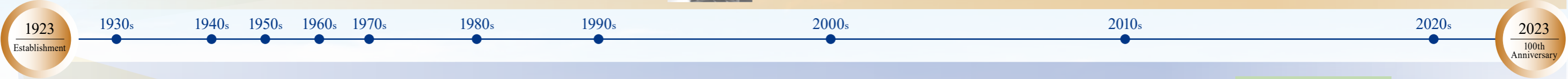





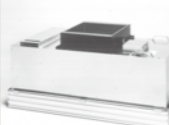
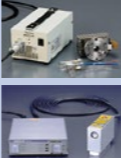



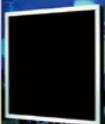

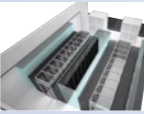

1982 SECTA (saving energy computer of Takasago) P-1000*	
1983 DELTA (highly-accurate control technology) B-4000*	
1987 Failure predictive maintenance system for bearing, SIGMA T-3200*	

2005 MAT® (total system for measurement, analysis, and evaluation)	
2005 GODA® (data collection and analysis tool to achieve energy operation)	





2014 MOTs® (consolidated equipment management tool)	2017 GODA® CLOUD 
2015 Gdoc® (centralized monitoring and control system)	2018 省エネ管太郎® (Shoenekantaro) 2.0 (software) 

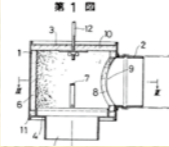

Industrial solutions – Equipment / Systems

1927 Temperature and humidity adjustment system for artificial silk factories 	1968 Vertical laminar flow clean room 	1984 TCR®-MP system 	1995 Soft X-ray static ionizer (IRYSYS®) 	2005 Swirling induction type TAKASAGO HVAC system (SWIT®) 	2010 Data center operation service (Green Air® IDC) 
1930 Takasago Ebara turbo refrigerator completed 		1988 Super ice system* 	1996 Chemical filter (TIOS®) 	2006 High-stability, low-pressure difference control systems (LO-VST®) 	2011 Wall outlet-type air conditioning system for data centers (IDC-SFLOW®) 
1938 First domestic cooling tower 	1940 -75°C super low temperature system 		1997 Energy-saving, dry type dehumidifier (WINDS®) 	2007 Super low dew point clean air supply system (CDASS®) 	2011 TCR-SWIT® 
	1971 PMAC cassette system developed* 		1998 Chemical washer (T-GET®) 	2009 BARRIFLOW®/BARRIHOOD® 	2012 Nitrogen dioxide gas sterilization service started (TSCLOO®)* 
					2015 Air supply and exhaust management system for fume hoods (i-Fume™) 
					2015 Super ice system for high freshness (SIS-HF®)* 

Construction technologies

1959 Full-scale hotel construction started New fan coil units adopted	1979 Vertical pipe shaft construction method for high rise buildings Other prefab construction methods adopted	1980 Patent for one-point hanging diffuser box 	1994-1995 District heating and cooling facilities that make effective use of unused energy source constructed	1995 Super ice system (ice thermal storage) adopted 	2003 Free cooling system adopted (Energy Center at the South Exit of Sapporo Station)	2013 Drainless flushing system 	2018 Aluminum refrigerant piping system* 
						2016 エルブレイズ® (El-brazed) method* 	

\* Not available and no sales in overseas



Initiatives on hydrogen innovations

Development of the hydrogen generation system through our own R&D

Takasago Thermal Engineering has developed a wide range of energy conservation technologies and construction technologies for the last century as an HVAC engineering company. We would like to introduce here our activities toward achieving carbon neutrality.

We have been working on the advancement of HVAC technologies and development of heat source for HVAC to achieve optimization of energy efficiency used in buildings. We have emphasized the development of generation and utilization technologies of hydrogen, which can be used for electricity and fuel as well as cold energy, in order to diversify energy uses.

Through these initiatives, in April 2020, we commercialized the small solid polymer water electrolyzer that can produce 1-5 Nm<sup>3</sup> of hydrogen per hour.

A hydrogen production system, Hydro Creator<sup>®</sup>, developed in-house



An on-site green hydrogen energy infrastructure system

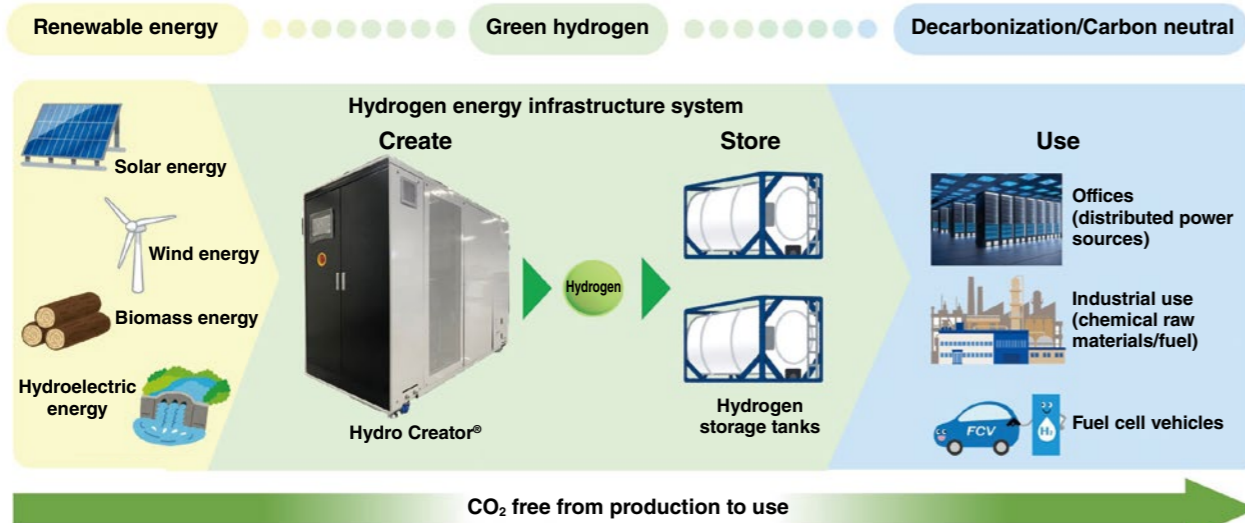

An entire landscape of the microgrid facilities in Atsuta, Ishikari City (photograph taken in December 2021)



A step toward space: Planet6.0 lunar resources development

We are also working on resource development for the lunar surface as a mid- to long-term initiative. You may wonder why an HVAC engineering company would work on a space project. It is a common consensus that huge business opportunities may be found in space and on the lunar surface for the private sector. In recent years, it has been indicated that there is a possibility that water exists on the moon, and so there have been movements to utilize that resource to help build the lunar economic zone. If we can generate hydrogen and oxygen from lunar water sources using water electrolysis technology, then we can use oxygen to sustain life and hydrogen as fuel for rockets and lunar rovers.

If we can obtain water sources on the lunar surface, we will be able to perform long-term activities, and we believe that this will be the frontier of the lunar economic zone. We are currently developing a water electrolyzer that will be the smallest and lightest in the world, intended for use on the lunar surface by utilizing the technologies employed in developing the small water electrolysis-based system. We have been developing the system to fit onboard a lunar ship developed by ispace, inc., a startup for the space industry, to conduct a demonstration experiment to generate hydrogen and oxygen on the lunar surface environment for the first time.

Adopted as a microgrid in Atsuta, Ishikari City

Ishikari City in Hokkaido has declared that they aim for a zero-carbon city. Our hydrogen generation system has been utilized for the microgrid project in Atsuta, which is located in the northern part of the city. The uniqueness of this project is that hydrogen is generated and stored by electrolyzing water with electricity generated by solar power, a renewable energy source. In the event of a disaster in the area, the stored hydrogen and other resources can be used to generate electricity for 72 hours and supply it to public facilities that will serve as disaster evacuation shelters. It is truly a sustainable, low-carbon microgrid that uses hydrogen (green hydrogen) energy coming from renewable energy as an energy source.

The microgrid in Atsuta, Ishikari City

- The microgrid uses solar power generation (163 kW) to supply electricity to five public facilities in Atsuta, Ishikari City
- In order to utilize solar power electricity to full potential, battery storage (50kW/168kWh) and a hydrogen system (water electrolyzer and fuel cells) are also built as a storage system.
- The microgrid is designed to use direct current within the grid to reduce electricity losses.
- In the event of a disaster, the microgrid is automatically controlled to shift to autonomous operation and sends electricity to the designated evacuation shelters for 72 hours or more.

Winner of the NIKKEI Carbon Neutral Zero Award 2021  
Grand Prize in Project Division



Lunar exploration reference image

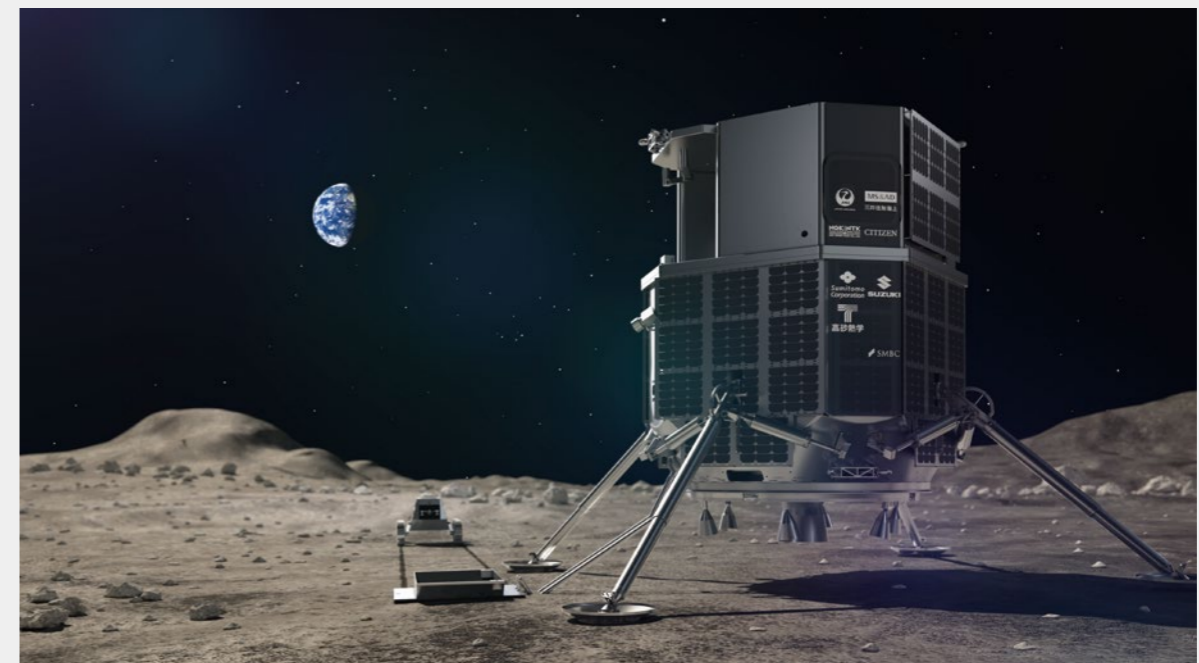

**List of environmental burden reducing technologies using Green Air® technology**

A reduction in the burden on the environment is achieved by using characteristic Green Air® technology from the planning, design and construction of air conditioning equipment through to its operation, management and renewal work. We make efforts to create environments in a way that will satisfy customers by simultaneously pursuing both an increase in comfort and a reduction in the environmental burden.

**Industrial air conditioning**

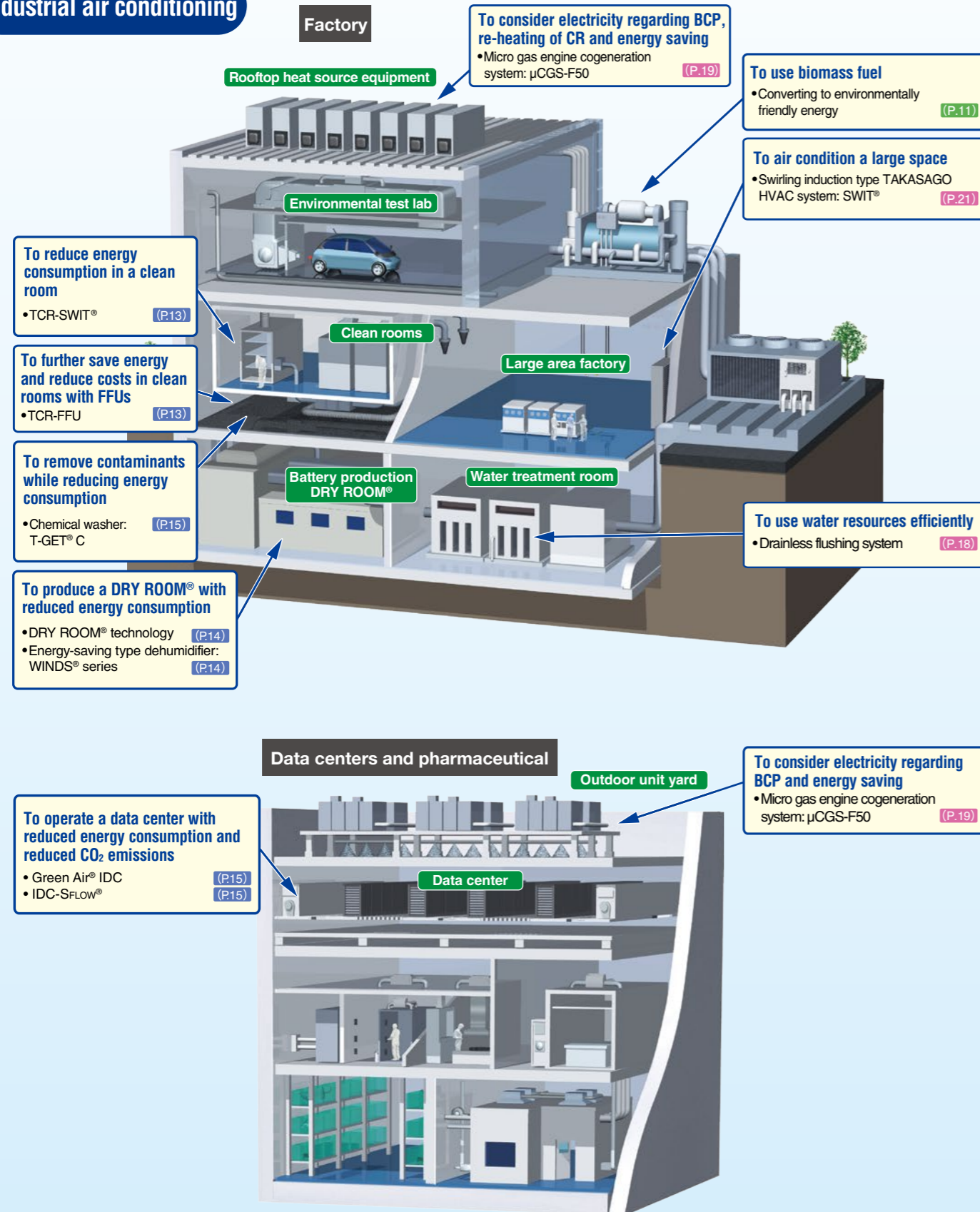

**General air conditioning**

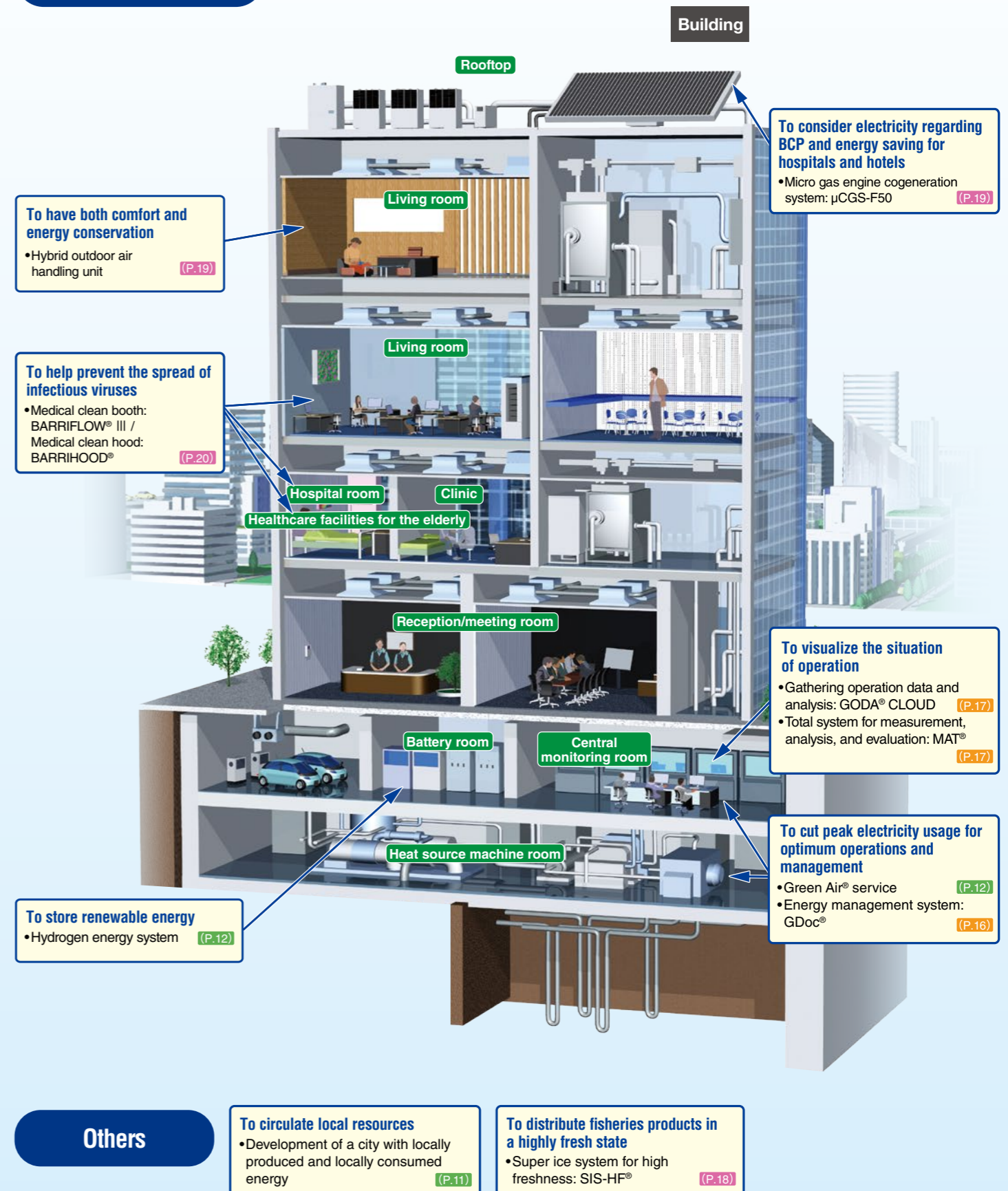



Converting to environmentally friendly energy



Converting to environmentally friendly energy (biomass)

We optimize energy solutions achieved from our thermal engineering technologies. Starting with the ZEB technologies adopted in our Innovation Center, the needs for utilization of community-sourced energy such as environmentally friendly energy using wood biomass and herbaceous biomass, which can contribute to achieve carbon

neutrality, as well as local resources such as sewage sludge, will increase in the future. For our clients to achieve optimization, we provide extensive and comprehensive feasibility studies followed by implementation, right through to operational support of the proposed environmental solutions.

Concept of a carbon neutral system using biomass boiler

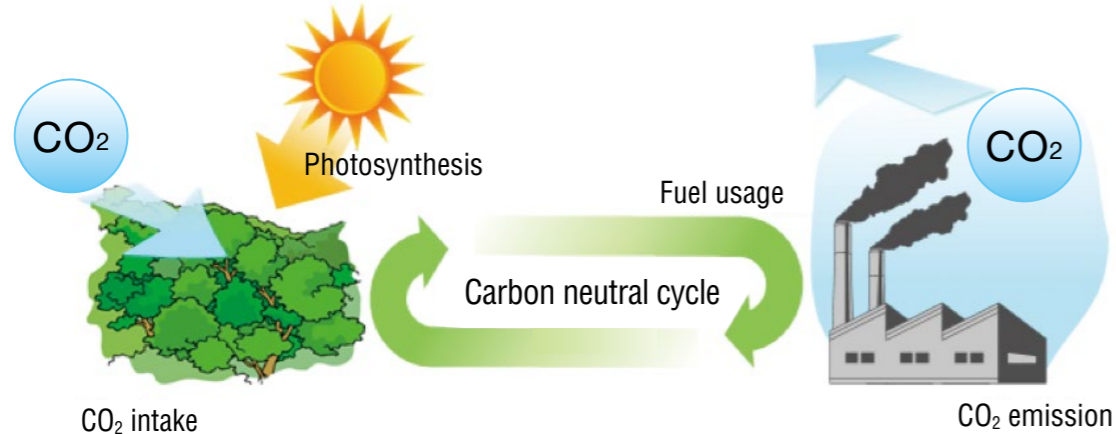

Development of a city with locally produced and locally consumed energy



Development of a city with locally produced and locally consumed energy: regional revitalization and local energy from biomass

For Japan, a country which has low self-sufficiency for energy, circulation of local resources is an important topic. Shifting from fossil fuels to utilization of autonomously distributed electricity and heat sources using biomass will not only contribute to progress towards a decarbonized society, but also improve community resilience and promote revitalization of local economies.

We hope our thermal engineering technologies will create new coordination among businesses and local municipalities for opportunities and trigger the promotion of municipal development through locally produced energy for local consumption.

FY2018, 2 projects received cost grants, as promotion projects, for the feasibility studies into the commercialization of locally produced energy for local consumption by employing regional resources by the Ministry of Economy, Trade and Industry

FY2018, 1 project received a project grant for the locally independent systems using biomass energy verification by the Ministry of Economy, Trade and Industry

FY2019, 1 project received a project grant for the distributed energy infrastructure master plan drafting by the Ministry of Economy, Trade and Industry

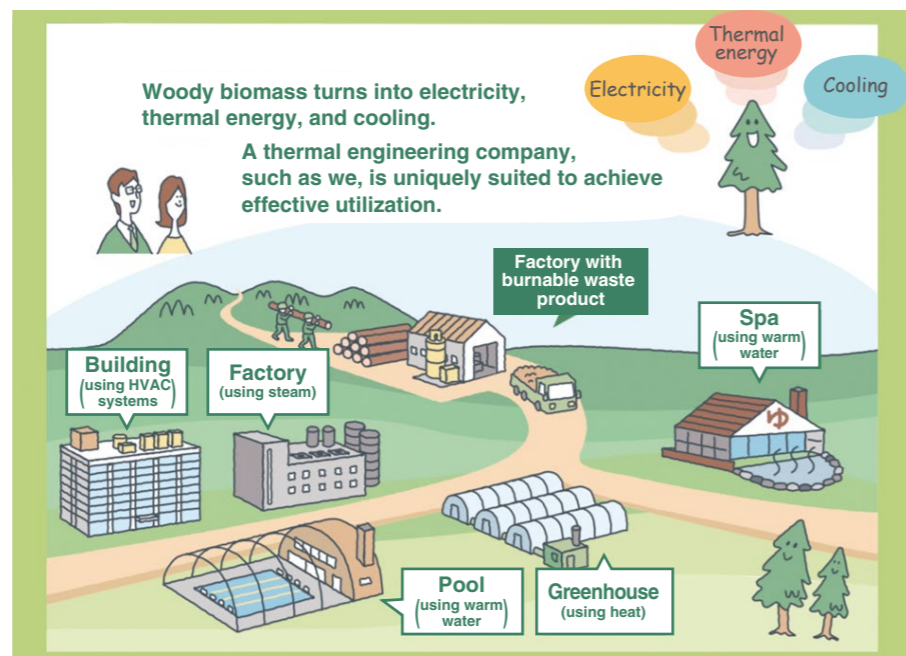

Green Air® service



Creating new services that synergize with our technologies through data analysis

While rapid IoT introduction is ongoing in various areas, the IoT wave is gaining momentum in the area of building equipment as well. We utilize IoT devices such as sensors to collect operations data for building equipment and environmental data for indoor spaces on our smart platform, and offer the optimal facilities operations based on analysis of the results. Furthermore, from the diverse data that has been accumulated, we are working on creating new services that utilize next-gen environmental control systems and facilities operations systems as well as artificial intelligence to accelerate the development of these services for practical use.

[Use cases]

- Visualization of thermal environment
- Online efficiency assessment for heat source equipment
- Facilities operations data analysis through machine learning
- Assessment of operation and failure detection of equipment systems

Concept image

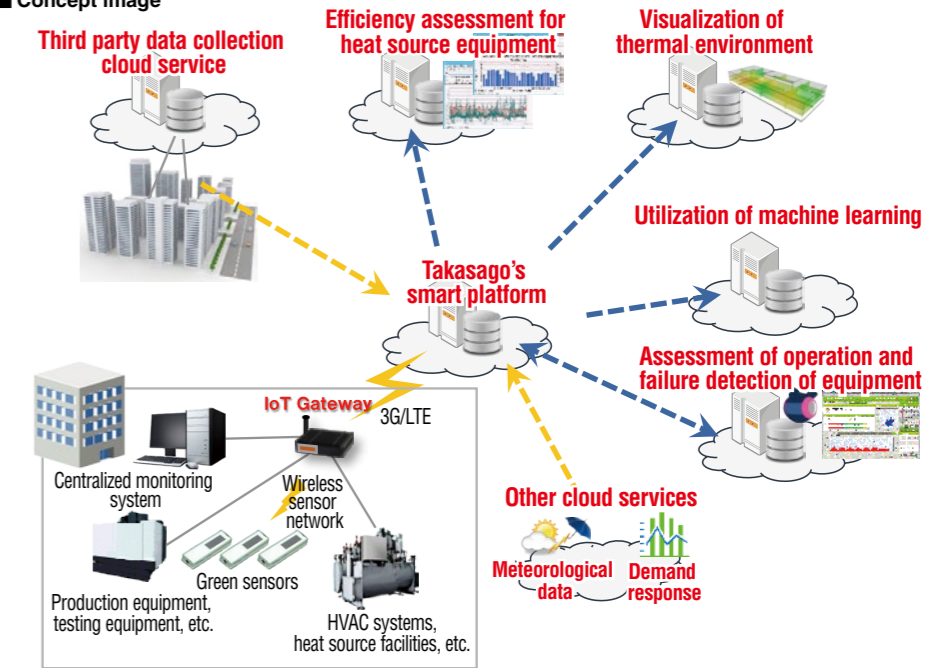

Hydrogen energy system



Supplying electricity, heat, and hydrogen (fuel) after recharging with renewable energy

This electricity storage equipment supplies a variety of energy types by using hydrogen energy, which is attracting attention as one of the technologies available to solve environmental problems. It is suitable to convert output, absorb excess electricity, supply energy in emergencies including blackouts, and supply carbon neutral fuel, all from renewable resources which are expected to be used more and more on a global scale in the future.

- The production and storage of hydrogen using power from renewable energy. Hydrogen is used on an as-needed basis.
- There is no heat loss due to involuntary discharge, so long-term power storage ranging from months to years is possible.
- The role fossil fuels have been playing can be replaced by hydrogen.

Introduction image of a water electrolysis-based hydrogen production system "Hydro Creator"

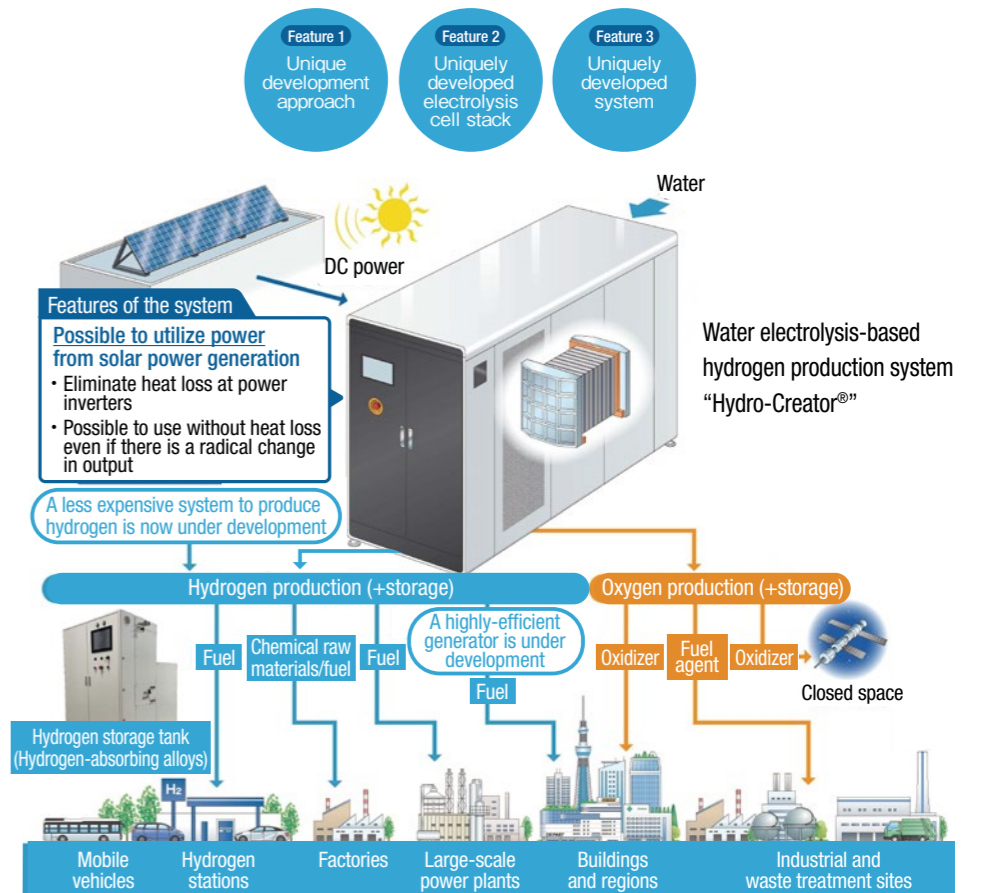

Patent No. 4919314, Patent No. 5152948, Patent No. 5492460, Patent No. 5622544

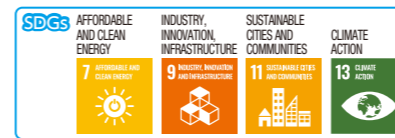

TCR-SWIT®



Constructs a high-precision environment in an ultra-short execution period while also providing energy and cost savings

Applying to clean rooms

TCR-SWIT® is a next-gen clean room technology which makes it possible to achieve both effective indoor environment maintenance and energy savings in large-scale clean rooms, which had previously been a major challenge. The special features of SWIT® have been technically tested and verified in an ultra-precision air-conditioned clean room of ISO Class 5; we demonstrated that thermal environments and cleanliness can be maintained with less air flow by means of excellent ventilation efficiency. We have an established track record of commercial installation in a semiconductor manufacturing process (front-end) clean room (ISO Class 5 ultra-precision air conditioning).

TCR-SWIT® installation example



Constructing a TCR-SWIT® experimental and testing site

We constructed an experimental and testing site for TCR-SWIT® in the Takasago Thermal Engineering Innovation Center. It is the one and only experiential site in the world where you can switch between a TCR-SWIT® method and FFU method in the same room and visualize temperature distribution, cleanliness, air flow, etc. so that you can compare and test. It has a mobile mock load of heat generation and can recreate an environment that is close to the actual device layout and heat generation status.

Since we opened the site, many clients from various fields came to experience the HVAC system of TCR-SWIT® and it has received positive feedback.

TCR-SWIT®: Takasago Clean Room Swirling Induction Type

Patent No. 5361140, Patent No. 6636859, Patent No. 6878552, Patent publication No. 2020-056570, Patent publication No. 2020-060366, Patent publication No. 2020-106230, Patent publication No. 2020-106231, and more

TCR-SWIT® verification testing (applied to ISO Class 5)

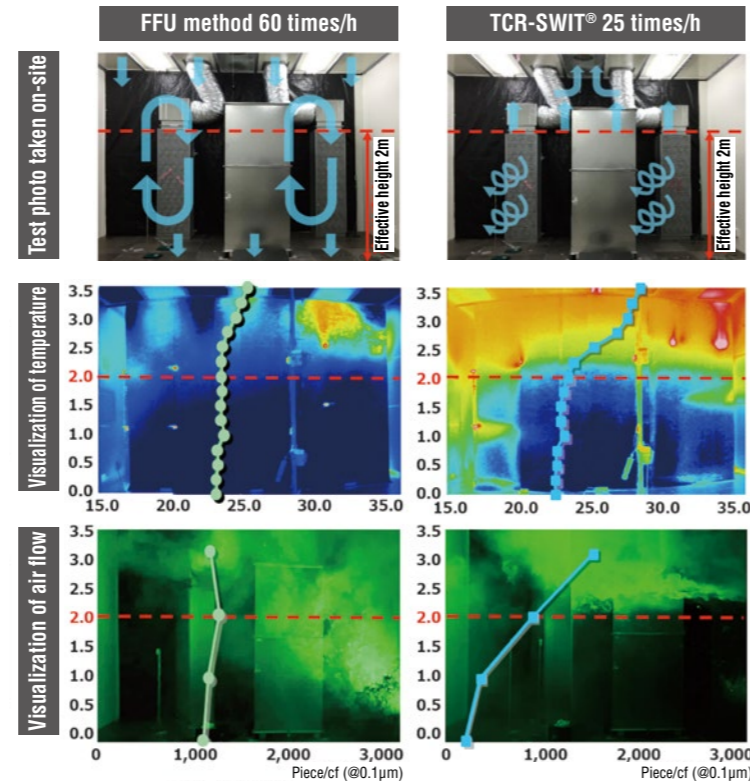

TCR-SWIT® experimental and testing site



TCR-FFU



Further energy saving and reducing costs in clean rooms with FFUs

Utilization of brushless DC motors

We have achieved energy conservation in clean rooms with the use of highly efficient brushless DC motors. The number of rotations of DC motors can be set in increments of each 10 rpm, achieving even more energy conservation during operation.

Utilization of aluminum casing

Aluminum is more lightweight than galvalume steel sheets. Lighter weight makes to increase the size of each FFU and reduces total number of FFU installed, and further saves energy and reduces costs.

Specifications (example)

Module: 1,200×1,200  
Surface air velocity: 0.4 m/s  
Noise level: 52.9 dB (A)  
Weight: 37.8 kg  
Airflow rate: 30.7 CMM×150 Pa  
Power consumption: 4.0 W/CMM  
Power: 1φ×200 V

Appearance of TCR-FFU



Controller



\*Started sales for branch offices from October 2022  
TCR-FFU: Takasago Clean Room Fan Filter Unit

DRY ROOM® technology



Achieving low-cost and energy-efficient DRY ROOM® facilities with appropriate equipment configuration and optimal operational control

Moisture in the air is an impediment to yield improvements in the manufacturing processes for the increasing production of rechargeable lithium-ion batteries and next-gen secondary batteries, which are expected to be widely used in the future. This manufacturing is therefore performed in a DRY ROOM®, which has the moisture in the air removed in a controlled low dew point environment.

The manufacturing cost for the dehumidified air used in the DRY ROOM® is higher than that for the conditioned air used in ordinary air conditioning. There are therefore increased demands for energy conservation in large-scale mass production factories. In order to respond to these demands, we optimized the configuration of the dehumidification equipment to achieve reduced energy consumption and lower cost. In addition, we achieve further reductions in energy consumption by implementing optimal operation controls to deal with the periods when the dehumidification load is low, for example, during the winter months.

Basic configuration of the DRY ROOM®

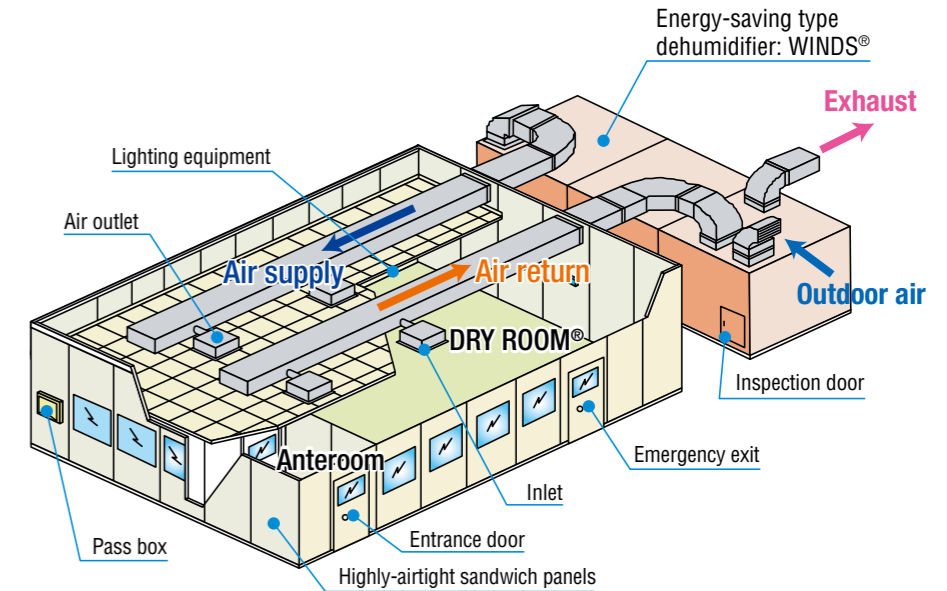

Patent No. 4754358, Patent No. 4990443, Patent No. 5587571, Patent No. 5681360, Patent No. 5681379, Patent No. 5684478

Energy-saving type dehumidifier: WINDS® series



Greatly reduces energy consumption and costs in the supply of dry air for rechargeable battery manufacturing processes

The WINDS® series products are low dew point dehumidifiers that supply dry air with a dew point temperature of between -50°C and 70°C to a DRY ROOM®. In a DRY ROOM®, the original dehumidification flow and optimal design technologies contribute to lower energy consumption.

Energy-saving type dehumidifier: WINDS®

High-performance energy-saving type dehumidifier: WINDS®-II

A high-performance dehumidifier that has just a single-stage rotor, but achieves dehumidification performance comparable to that of a two-stage rotor dehumidifier

Low-temperature regeneration type dehumidifier: WINDS®-III

This can supply dry air with a regeneration temperature of 80°C or less, which is a far lower temperature than that of conventional dehumidifiers (regeneration temperature: 140°C)

Up to a 60% reduction in energy consumption versus conventional dehumidifiers is made possible by utilizing unused low temperature exhaust heat at less than 90°C

Energy-saving effect of WINDS®-III

	Conventional dehumidifiers	WINDS®-III
Heat source	Electric heater	Unused exhaust heat
System configuration		
Regeneration temperature	140°C	80°C
Energy cost percentage per year	100%	40%

[Main calculation conditions] Dew point: Supply air < -50°C, return air -30°C Outdoor air conditions: Standard weather data of Tokyo Refrigerator COP: 4.0

WINDS®: W-roter Innovational New-Dehumidify-System

Patent No. 5390242, Patent No. 5570717, Patent No. 5576619, Patent No. 5587571, Patent No. 5681379, and more

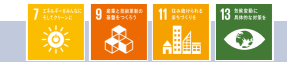
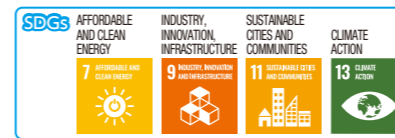

Chemical washer: T-GET®C



The industry-leading original device to remove soluble gas: Chemical washer

Chemical washer is an air washer installed on outdoor air handling units in order to prevent gaseous pollutants contained in the outdoor air from infiltrating the clean room. Compared to the conventional units, T-GET®C can minimize the air pressure loss by 60% and unit length by 50%, which in turn makes it possible to reduce blower force and space required for installation.

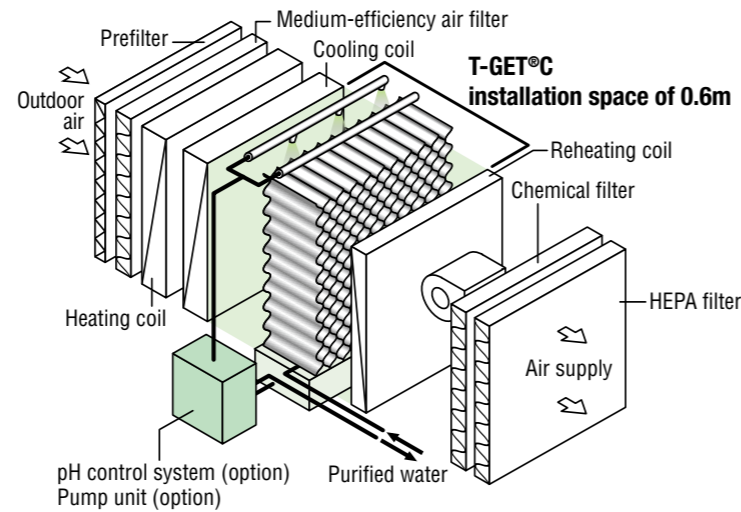

Removal performance

Removal performance (annual average value)	
Ammonium ions NH <sub>4</sub> <sup>+</sup>	90%
Sulfate ions SO <sub>4</sub> <sup>2-</sup>	85%

T-GET®C: Takasago Gas Eliminator

Patent No. 462559, Patent No. 4757765

Green Air® IDC and IDC-S<sub>FLOW</sub>®



Air conditioning system for IDCs that achieves both conservation of energy and thermal environment: IDC-S<sub>FLOW</sub>®

IDC-S<sub>FLOW</sub>® is an air conditioning system for IDCs, which consists of wall air outlets, flow control mechanisms (cold aisles), and shielding plates for hot aisles. Air supply is provided via the flow control mechanism, which means the wind speed on the air supply surface on the racks is equalized to a low flow.

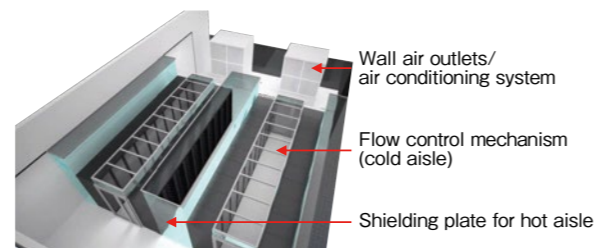

Winner of Green IT Award 2012 "Judging Committee Special Award"  
 Winner of the 13th Industry-Academia-Government Collaboration Contribution Award "Ministry of the Environment Award"  
 IDC-S<sub>FLOW</sub>®: Internet Data Center Side Flow System  
 Patent No. 5743536, Patent No. 5748469, Patent No. 5926030, Patent No. 6049981, Patent No. 6117500, China Patent No. 102538161, and more

Features (compared to common wall outlet type air conditioning systems)

- High energy conservation:**  
Reduces the flow back of the rack exhaust heat, and the air supply temperature can be set quite high
- Adjustment is easy:**  
Air flow adjustment depending on the heat generation status is unnecessary
- Good operability:**  
Draft is reduced near the air outlets in the cold aisles

Comprehensive assessment technology for IDCs and operation task service for the entire life cycle of IDCs: Green Air® IDC

Green Air® IDC employs our comprehensive assessment technology for service of operations tasks in order to optimize an IDC's overall performance throughout its life cycle.

The air conditioning load at IDCs changes frequently due to the introduction of new IT equipment and the replacement of old equipment. It is necessary to adjust the air conditioning equipment according to the situation of heat load, but advanced knowledge and know-how are imperative for this operation.

We have proven results in more than 100 tested installations located both in Japan and overseas. The service diagnoses the thermal environment and energy use of the operating IDCs.

For an IDC that is already in operation, we diagnose the thermal environment and energy so that we can offer a one-stop service, i.e. support for everything from energy-saving tuning, overall renovation planning and design to the construction work and after-sales support.

Bird's eye view of the entire server room by a thermal-imaging camera

The service narrows down areas where thermal problems are likely to occur.



Patent No. 5306969, Patent No. 5306970, Patent No. 5324363, Patent No. 5421570, Patent No. 5729993, and more

Energy management system: GDoc®

A comprehensive support service for optimal operation of heat source and HVAC systems

Green Energy Management Doctor, GDoc®, is software that provides optimization for facility operations over the entire building life cycle. GDoc® is equipped with an AI (artificial intelligence) rule engine that is capable of extrapolating optimal control setting values based on measured values and operations knowledge.

The software comes in three kinds, premium (outputting control setting values for a heat source equipment), DHC (district heating and cooling, outputting start/stop schedules of a heat source equipment), and Building Automation (BA) System (centralized monitoring system).

GDoc®: Green Energy Management Doctor

Trademark No. 5740247

(1) GDoc® advance  
 Patent No. 7029881,  
 Patent publication No. 2021-169922

(2) GDoc® premium  
 Patent No. 6787726, Patent No. 6750980, Patent No. 6849345,  
 Patent No. 6982146, Patent publication No. 2018-031534

(1) GDoc® premium

A real-time control system using the rule engine (AI)

With the built-in rule engine, GDoc® premium is able to generate control setting values for the heat source equipment and heat conveyance to help save energy and reduce costs while maintaining the given conditions and also taking external air conditions into account.

Control logic can be established using a standardized optimization module, supporting operational improvement based on existing facilities, device and system enhancement, and rapid, flexible program tuning.

With the addition of interactive building energy management system (BEMS) feature as an option, GDoc® premium provides visualization of the energy consumption, and system performance and maintenance information of the HVAC system. GDoc® premium provides optimization of facility operations over the entire building life cycle.

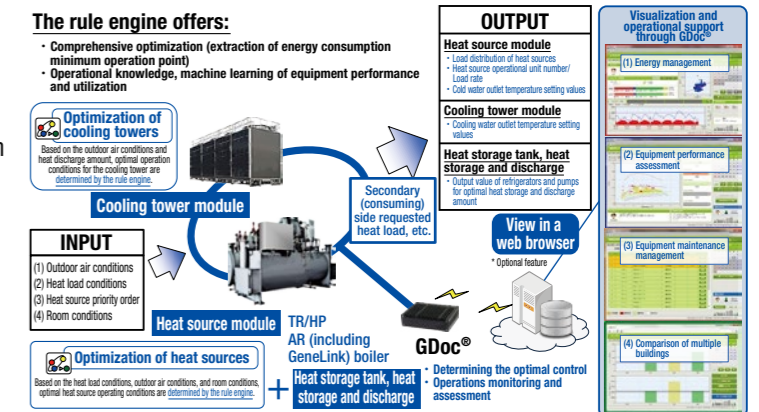

(2) GDoc® DHC

A heat source automatic operation control system for large heat storage tank facilities

GDoc® DHC is a heat source automatic operation control system for those who own large heat storage tanks such as a district heating and cooling plant. The system calculates the appropriate amount of heat storage based on the load forecast and automatically outputs the heat source start/stop schedules required to achieve the target heat storage.

The system is built with rules based on operational information from experts, which means it can flexibly respond to complex heat source operations. GDoc® DHC contributes to both stable operation of plants and labor saving.

Instead of operators, AI automatically creates an operation plan for heat sources based on various information, automatically outputting operation schedules.

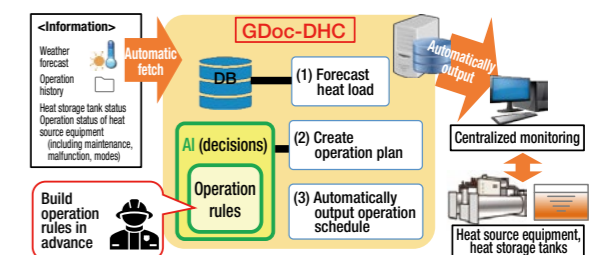

By building operation rules based on hearing in advance, AI achieves complex decisions generally done by operators.

(3) GDoc® BA System

A centralized monitoring system with an open network that achieves optimal control by connecting with the rule engine (AI)

GDoc® BA System is a centralized monitoring system that can connect to various control systems due to the use of the open network. It provides a suitable system according to each customer's needs. Combining this open system with GDoc® premium of the GDoc® series achieves optimal control through the rule engine (AI) as well as the monitoring control feature, contributing to energy conservation and cost savings over whole life cycles of buildings.

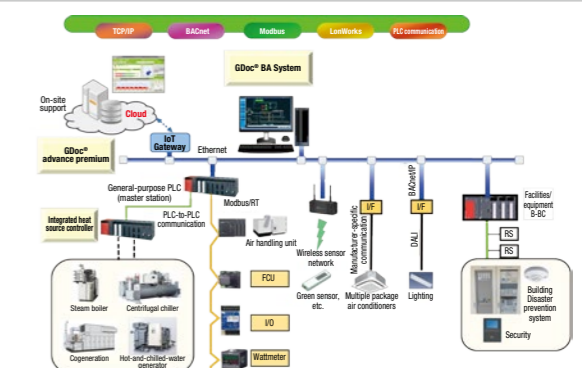

Gathering operation data and analysis: GODA<sup>®</sup> CLOUD



Infrastructure tool which resolves social concerns of energy conservation, lack of on-site data analysts, and IoT utilization

GODA<sup>®</sup> CLOUD is a cloud-based energy analysis tool that analyzes on-site energy usage and operating data of HVAC systems, etc., in order to promote more efficient energy conservation management.

Operation data is collected from on-site central monitoring equipment and inputted into a dedicated database in the cloud. Data analysts are able to direct and assist on-site operators without having to be on-site themselves by remotely checking and analyzing the data. Operations improvement is performed by sharing information with on-site operators, facilitating energy conservation and life cycle cost reductions.

Usage model for remote assistance in energy conservation tuning

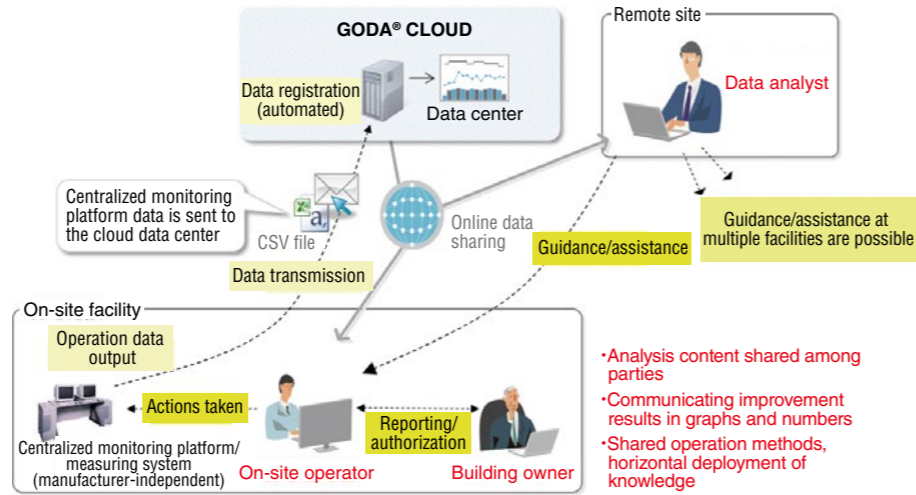

•Winner of the 2017 "Good Design Award for Best Platform" GOOD DESIGN AWARD 2017

•Winner of the 2017 "Energy Conservation Award for Best Product or Business Model" Winner of the "Energy Conservation Center Chairman's Award"

Compensating for lack of analysts by cloud data collection

"Operations improvement" will be achieved via remote analyst guidance even without an on-site analyst.

GODA<sup>®</sup>: Gathering Operation Data And Analysis

Patent No. 4540737

Total system for measurement, analysis, and evaluation: MAT<sup>®</sup>



Provision of the information necessary for decisions on the update of equipment and devices

MAT<sup>®</sup> is a technology that enables the monitoring of a facility's operational status and the assessment of its performance using virtual design values while maintaining the facility's normal functionality.

Using specifically developed precision-verified surface measurement technology (measuring temperature, flow, and electric current), MAT<sup>®</sup> is able to utilize accurate data with measurement error factors removed, facilitating analysis and assessment of facility performance. By enabling a system's users to grasp the actual state of facility performance and energy consumption, MAT<sup>®</sup> helps them achieve more efficient operations and determine when equipment needs updating.

- Obtaining operational data through surface measurement
- Using the measured values to analyze equipment, system performance, and energy usage
- Supporting comparison of analysis results with standard values

Example of measurements around a centrifugal chiller

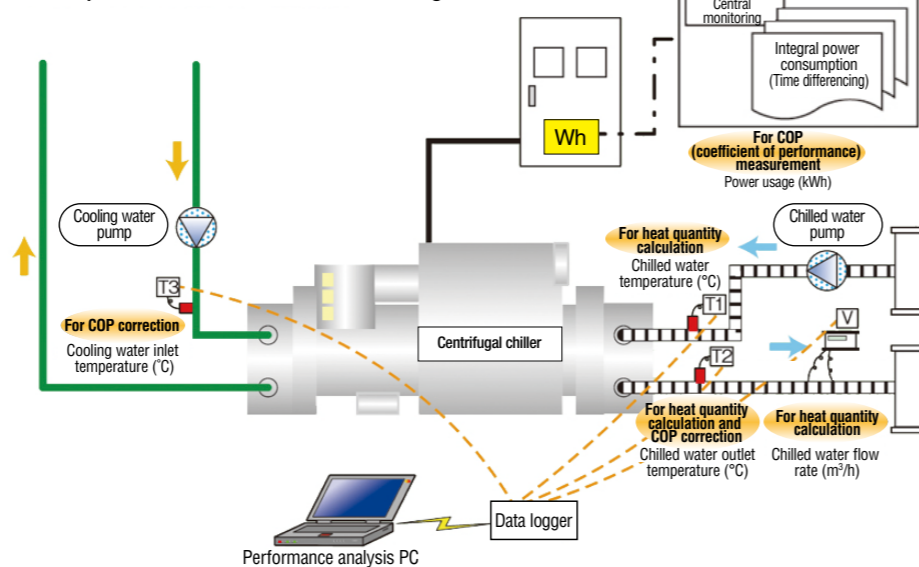

MAT<sup>®</sup>: Measurement Analysis Evaluation Totalized System

Patent No. 4694185, Patent No. 4796283, Patent No. 4948079, Patent No. 4949081, Patent No. 4949892, Patent No. 5185429, Patent No. 5749422, and more



Drainless flushing system



A system that flushes without any water drainage, reducing the burden from pollutants on the environment

This water treatment system makes it possible to perform flushing without draining water from the system by removing suspended matter such as welding debris and, at the same time, purifying the water in the pipeline. This method is environmentally friendly as pollutants, such as zinc, contained in the flushing water are not released into the environment.

- Environmentally friendly water treatment system that does not discharge contaminant matter
- Greatly reduces the work needed for supplying and draining water, etc., for system flushing
- Reduces the flushing process control work and the overall costs

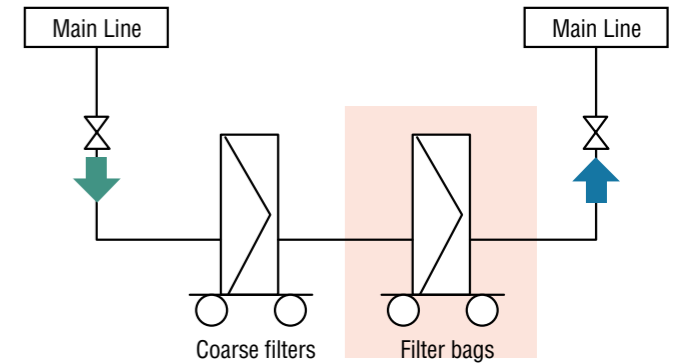

Bag filter unit

(A filter equivalent that is generally available on the market)

Winner of the 31st "Technology Promotion Award" by the Society of Heating, Air-Conditioning and Sanitary Engineers of Japan  
Winner of the 16th "Environmental/Facilities Design Award" by the Association of Building Engineering and Equipment

Patent No. 6105220, Patent No. 6113997, Patent No. 6285504, Patent No. 6524032

Super ice system for high freshness: SIS-HF<sup>®</sup>



Ice-making system that uses the supercooling phenomenon to produce sherbet-like ice that is as fine as snow

SIS-HF<sup>®</sup> uses the ice-making technology used for heat storage that we acquired through HVAC systems development. The system aims to achieve effective use of declining aquatic resources and increase profits for fishers by transporting very fresh aquatic products as is. The SIS<sup>®</sup> series has been implemented by many Japanese fishery companies.

Kunigami Fishery Cooperative



SIS-HF<sup>®</sup>: Super Ice System for HIGH FRESHNESS

Patent No. 6339441, Patent No. 6383037, Patent No. 6463399, Patent No. 6480103, Patent No. 6542814, Patent No. 6542815, Patent No. 6612904, and more

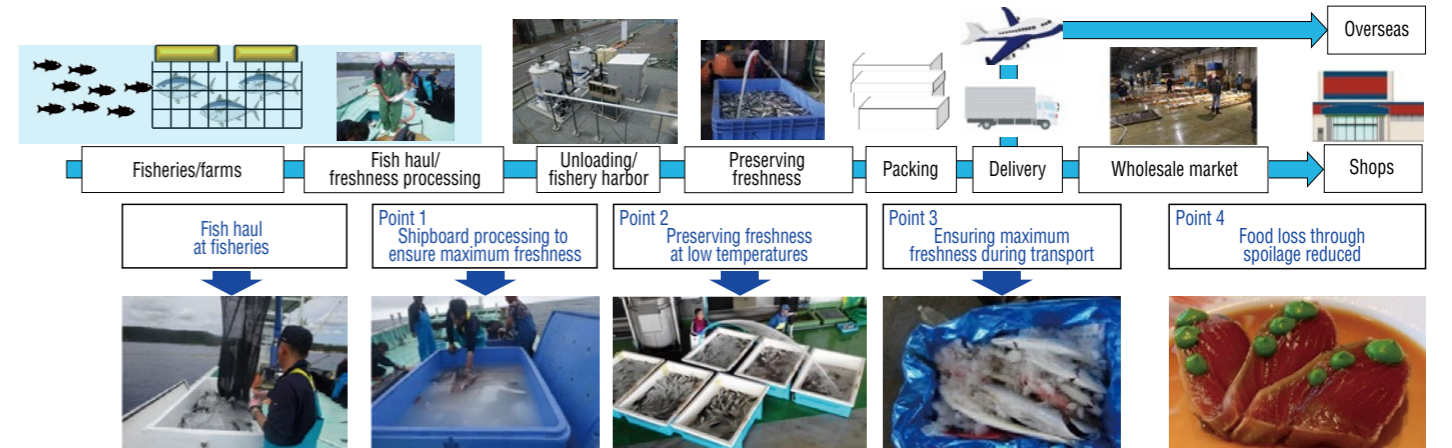

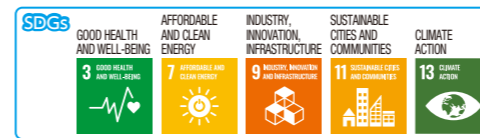

Hybrid outdoor air handling unit (in development)

A dual-pipe HVAC system that enables dehumidification and humidification in mid-temperature water NIPPON PMAC Co., Ltd.

A hybrid outdoor air handling unit can achieve an indoor environment equivalent to a four-pipe/six-pipe system by using a dual-pipe system with a built-in heat pump. Combining the system with mid-temperature chilled water coils enables energy saving with minimum refrigerant use.

The efficiency of the heat source increases by operating the system in mid-temperature water (15–35°C). For example, if the generation temperature of cold water is raised from 7°C to 15°C, a 20% increase in efficiency can be expected.

We are actively developing the hybrid outdoor air handling unit to make it a latent heat processing system that can dehumidify/humidify as well as adjust both temperature and humidity so that we can achieve improvements in productivity and comfort by a latent heat/sensible heat separated HVAC system.

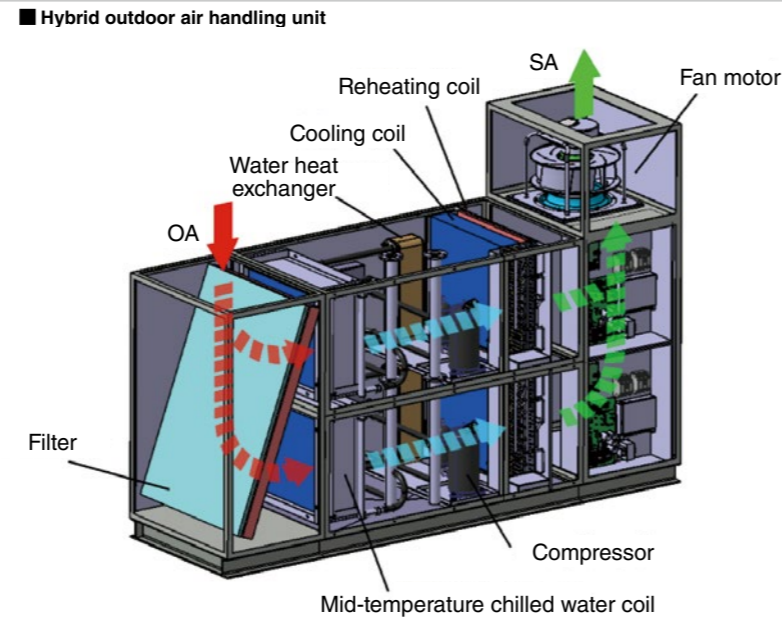

Micro gas engine cogeneration system: μCGS-F50

The world's best power generation efficiency: 50kW output, over 40% power generation efficiency, over 90% overall efficiency achieved TMES Co., Ltd.

μCGS-F50 was developed to provide solutions for the challenges that conventional micro CGS (cogeneration systems) were facing. In short, (1) it has achieved improvement in the efficiency of power generators; (2) expansion of uses and extension of operation hours through improvements in the utilization rate of exhaust heat; (3) improvement in maintainability as well as ensuring redundancy. Here are the characteristics as follows.

- High efficiency of over 40% power generation efficiency has been achieved.
- Reduction of surplus exhaust heat by reducing heat-to-electricity ratio.
- With BCPs purpose in view, our uniquely developed mixer easily switches fuel types (semi-auto switching: LPG/city gas/biogas).

The development is backed up by NEDO's aid project JPNP12004: FY2020 "Innovative program with strategic energy saving technologies/development for practical use/development of μCGS to achieve the world best generating efficiency" (aid granted to YGK Tsusho, Co-researchers: Takasago Thermal Engineering Co., Ltd. and TMES Corporation). The project finished in FY2022, and the product will be on sale from this fiscal year.

The generator unit and gas engine



Dimensions: 2,200×1,200×1,760H (Can be carried in via an elevator by splitting the system)



Built-in engine (3,500cc (four cylinders))

(Patent pending)

Medical clean booth: BARRIFLOW® III / Medical clean hood: BARRIHOOD®

Reduces infection risks for healthcare professionals with instant protection technology against infection/Reduces spread of infection with a quick isolation whose functions have been validated

Medical clean booth: BARRIFLOW® III

BARRIFLOW® III is a booth to be used for medical examinations, and it reduces the risk of droplet infection (instant infection) caused by coughs and sneezes for healthcare professionals. BARRIFLOW® III consists of a fan filtering unit, which removes viruses, etc. that float in the air, and a specially shaped vinyl curtained booth that shuts out coughs and sneezes, achieving both the safety of healthcare professionals and ease of medical examination.

- Air flow control suitable for medical examination
- Deterrence of droplets was validated through visualization of air flow and measurement of particles
- Used in hospitals and clinics for medical practice such as medical examination and sample collection
- Can be compactly folded unless being used (preparation for BCP)

Comparison of function with and without BARRIFLOW: Number of particles reaching to the mannequin



▲ When the function is disabled: About 25,000 particles

▲ When the function is enabled: 0 particles

Medical clean hood: BARRIHOOD®

BARRIHOOD® is a booth used to isolate an infected patient or a patient who may be infected. By covering the top half of the body with a negative pressure hood, the patient lying down can feel at ease without feeling cooped-up. The hood was designed based on the concerns of medical professionals, and is structured in a way that it does not inhibit the connection of an IV or dialysis machine.

- Isolation (shut out) was validated with influenza virus
- Compact, practical, economical, and easy to store
- Can be used as an isolation hood for an outpatient waiting room by switching the hood
- Used for individual isolation in medical wards, dialysis facilities, and healthcare facilities for the elderly
- Can be compactly folded unless being used (preparation for BCP)

Shut out validation

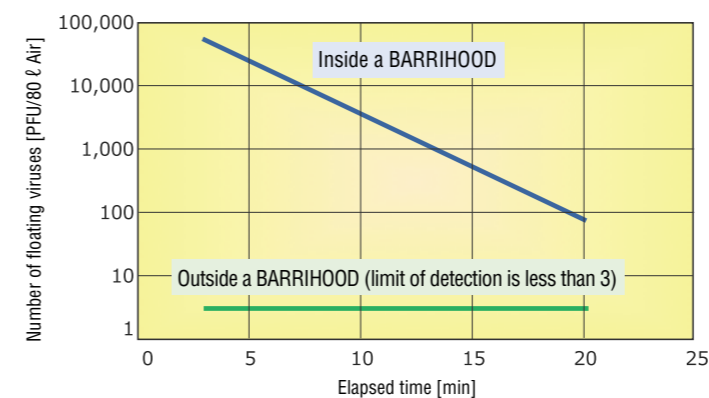

When the negative pressure is applied



Installed on a bed



Individual isolation in a large room

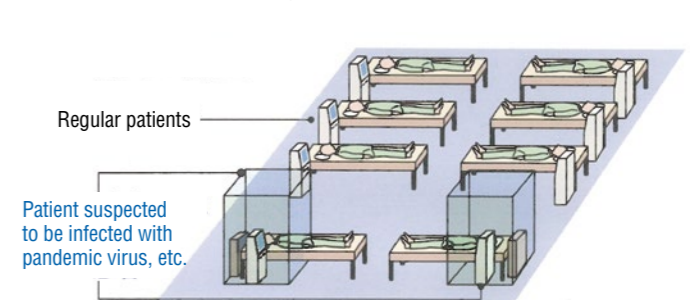

Winner of the 19th "Environmental/Facilities Design Award: Encouraging Prize" by the Association of Building Engineering and Equipment

Patent No. 5180024, Patent No. 5180032, Patent No. 5261046, Patent No. 5263697, Patent No. 5325007, Patent No. 5531340, Patent No. 5618169

©2023 Takasago Thermal Engineering Co., Ltd. All Rights Reserved.



## Swirling induction type TAKASAGO HVAC system: SWIT®

### Achieving both comfort and energy conservation with a 40% reduction in HVAC energy use

SWIT® is a displacement ventilation enhanced entrainment effect type HVAC system which uses the natural principle that warm air rises and cold air falls. The contaminated hot air is moved up to the ceiling and the environment in the working area is kept clean and comfortable.

SWIT® can condition the air with less air flow than a mixed air conditioning system as well as with the air flow temperature close to the room temperature. This makes it possible to build an HVAC system that conserves energy at a low cost. SWIT® is suitable for large spaces and places with high heat generation loads, high outdoor air loads, and high dust emissions.

Winner of the 7th "Environmental and Equipment Design Award"  
 \* Winner of the 24th "Technology Promotion Award" by the Society of Heating, Air-Conditioning and Sanitary Engineers of Japan and the 2012 Energy Conservation Grand Prize "Agency for Natural Resources and Energy Director-General"

SWIT®: Swirling Induction type TAKASAGO HVAC System

Patent No. 4421347, Patent No. 4574317, Patent No. 4790480, Patent No. 5053574, Patent No. 5053686, Patent No. 5490485, Patent No. 5780892, and more

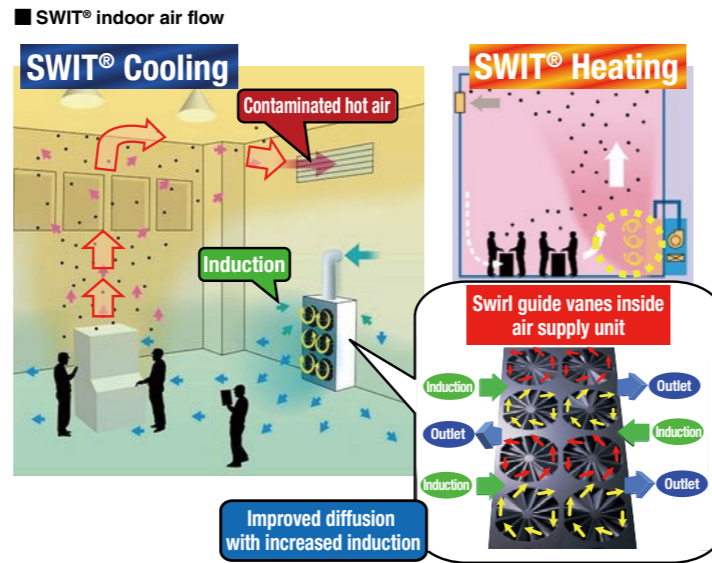

## Aluminum refrigerant piping system

### Contribute toward carbon neutrality and improve installation productivity

#### Purpose of development

- In response to the increased demand for copper due to the popularization of items including electric vehicles, we will convert refrigerant piping from copper to aluminum in order to contribute to achieving carbon neutrality.
- Aluminum pipes are about 1/3 the weight of comparable copper pipes. The support spacing for aluminum pipes can be 1.5 times bigger than copper pipes, and because of brazing, nitrogen purging is not required, resulting in an approximate 20% reduction in installation time compared to copper pipes.

#### Activity report in the Aluminum Plumbing Equipment Association (APEA)

- Following the standardization of aluminum refrigerant piping by APEA, Panasonic Corporation issued a press release announcing the industry's first manufacturer's warranty for commercial electric air conditioning equipment installed with aluminum refrigerant piping.

Awarding of the 36th Excellent Energy-Saving Award "Chairperson's Special Award of Japan Association of Refrigeration and Air-Conditioning Contractors"

Patent No. 7079618, Patent No. 7197319, Patent publication No. 2020-063791, Patent publication No. 2020-190381

#### An example of installed piping

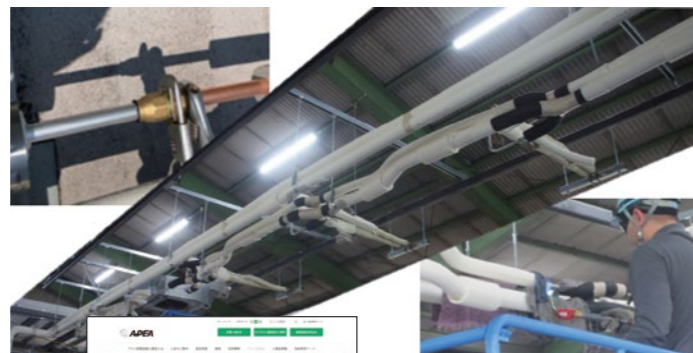

Website of the Aluminum Plumbing Equipment Association (APEA)

## COLUMN Development of a dry room

In the area of processing HVAC systems in factories, keeping a constant humidity as well as a constant temperature has been a frequent and historic demand, and improvements in their accuracy have been demanded even more.

In the late 80s, an environment with a very low dew point became required along with the demand increase for lithium batteries.

We call this very low dew point environment DRY ROOM® and proceeded with product development. (DRY ROOM® is our registered trademark.)

We newly developed a two-phase dehumidification unit that has a main dehumidifier and sub dehumidifier to be available for use in a dry room. The energy consumption for this was a lot lower than any existing technologies at that time.

The dry room technology is now used in the process of drying medications and semiconductor production as well as in the production process of new medications that require low temperature and low humidity.

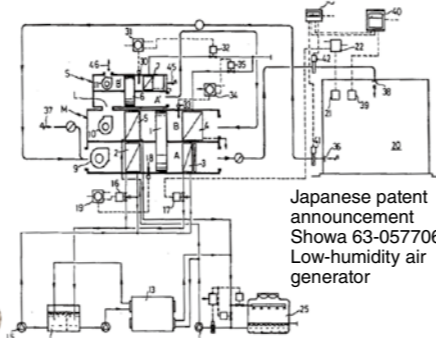

Japanese patent announcement Showa 63-057706 Low-humidity air generator

It's amazing to know that the word "dry room" was created by Takasago!

## TOPICS

### Takasago Thermal Engineering Innovation Center

Takasago Thermal Engineering Innovation Center (hereinafter referred to as "the center") opened in 2020 under the concept of "sustainable construction that reduces the impact on the global environment and improves intellectual productivity at the same time." The office area utilizes our own technology in the HVAC system and is open for observation.

#### Reduce the impact on the global environment: Aiming for "Nearly ZEB" by creating energy

As a facility to create energy, the center houses a solar power generator of 200kW as well as two wood biomass gasification generators of 40kW (100kW in heat quantity). Furthermore, the center has adopted lithium-ion batteries of 430kWh + 2,965kWh along with a NAS battery of 1,200kWh. This Tesla-made lithium-ion battery is the first lithium-ion battery of its size to be introduced in Japan (installed in March 2021). By utilizing renewable energy and storage batteries, the center aims for "Nearly ZEB," which reduces 75% or more of actual yearly energy consumption for the entire site.



#### Improve intellectual productivity: The highest Rank S achieved for CASBEE - Wellness Office

The center utilizes groundwater and exhaust heat from the biomass generators for desiccant outdoor air handling units and radiation air conditioners to save energy, as well as at the same time utilizes personal air conditioners operated individually via smartphones to achieve people-friendly air conditioning that matches individual preferences and work styles.

The center was awarded the highest rank of S for CASBEE - Wellness Office promoted by the Institute for Building Environment and Energy Conservation. The center also obtained BELS and LEED® certifications.

#### Status of obtained environmental performance assessment metrics



\*1 Certified in March 2020 \*2 Certified in July 2020 \*3 Certified in October 2020

\*1 BELS is a labelling system for buildings' energy conservation performance. [5 stars] for reducing design primary energy consumption by 91%.

\*2 LEED V4 BD+C (NC) is an environmental performance assessment system targeted at design and construction activities for new buildings and major renovations of existing buildings. [GOLD] (LEED® certification trademark is owned by the U.S. Green Building Council and is used with their permission.)

\*3 CASBEE - Wellness Office 2020 version. [Rank S]

#### For open innovation, address free & comfortable workspace.

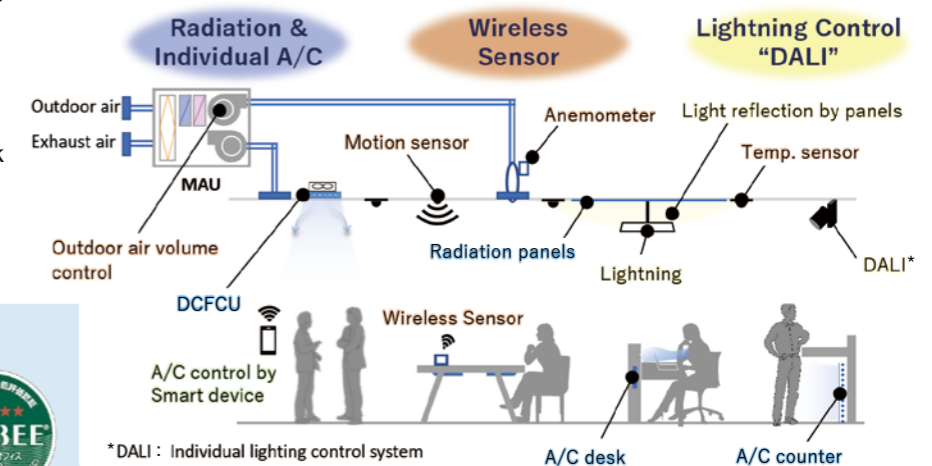

#### Experimental and testing site

We opened an experimental and testing site for TCR-SWIT® and IDC-S<sub>LOW</sub>® inside the center. Since it opened, many clients from various fields have visited the facility and the center has received positive feedback.

\* Experimental and testing rooms for TCR-SWIT® is introduced on P.13.



Experimental and testing site in the 2nd floor lab wing

